

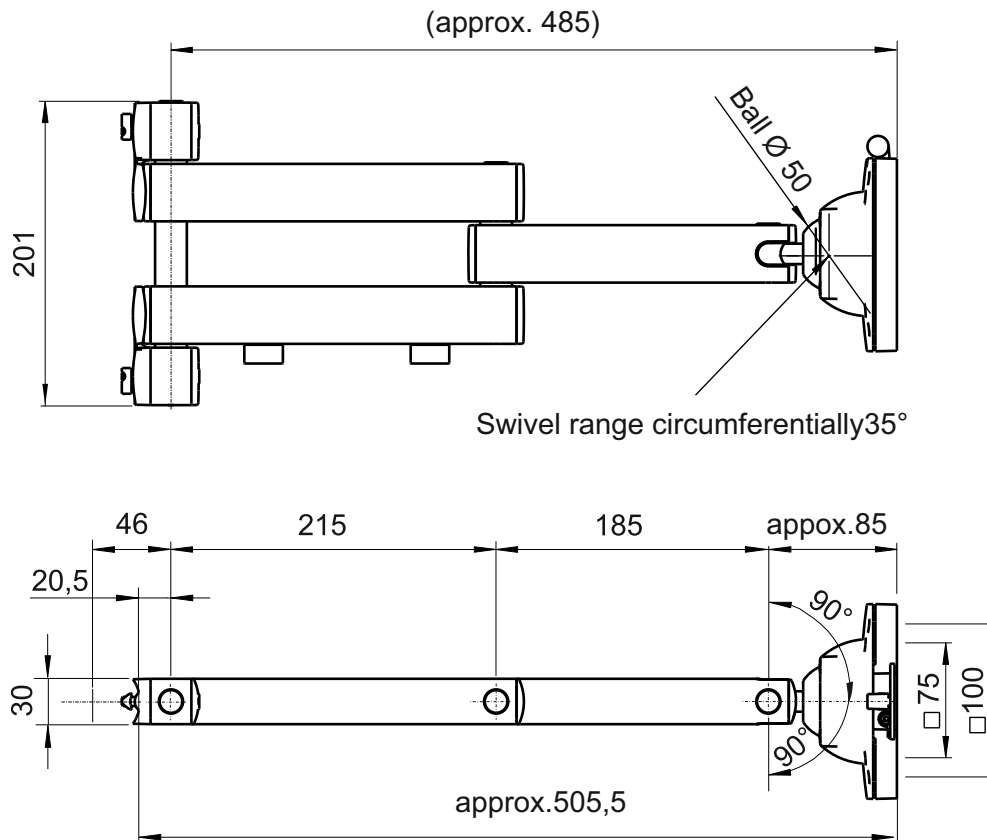

Monitor folding arm



| | | | |
|------------------|--------|--|--|
| Ref.. | 509204 | | |
| Width (mm): | 100 | | |
| Depth (mm): | 505 | | |
| Height (mm): | 201 | | |
| Net weight (kg): | 1.80 | | |

Description: Monitor folding arm

for flexible attachment of a monitor in the system grooves of Rocholz profiles with perforation, on support column (509001, 509002, 509006), on profile rail (509005) or upright adapter (509004), incl. cable holder

- VESA 75/100 quick-release attachment
- Load capacity 15 kg



Monitor folding arm

| | | | | |
|--------------------|---------------|--|--|--|
| Ref.: | 509204 | | | |
| Number of packets: | 1 | | | |
| EAN: | 4030177031893 | | | |
| Size WxDxH (mm): | 260x320x130 | | | |
| Weight (kg): | 2.50 | | | |

examples:
optional accessories



Keyboard and mouse holders with folding arm
Ref.:509201



Monitor support carriage
Ref.: 509202



Monitor folding arm
Ref.:509203



Support column with screw clamp
Ref.: 509002



Profile rail for folding arms for IT
Ref.: 509005

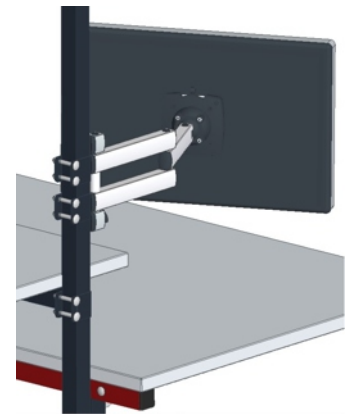

Upright adapter for attaching 509201, 509202, 509203
Ref.: 509003

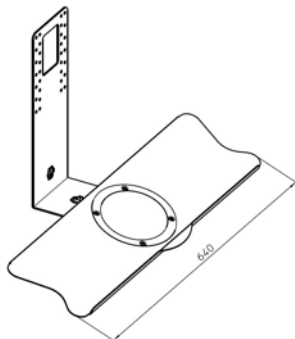

Keyboard adapter for mounting at screen folding arm
Ref.: 509205

Upright adapter for attaching 509204, 509207, 509209
Ref.: 509004