

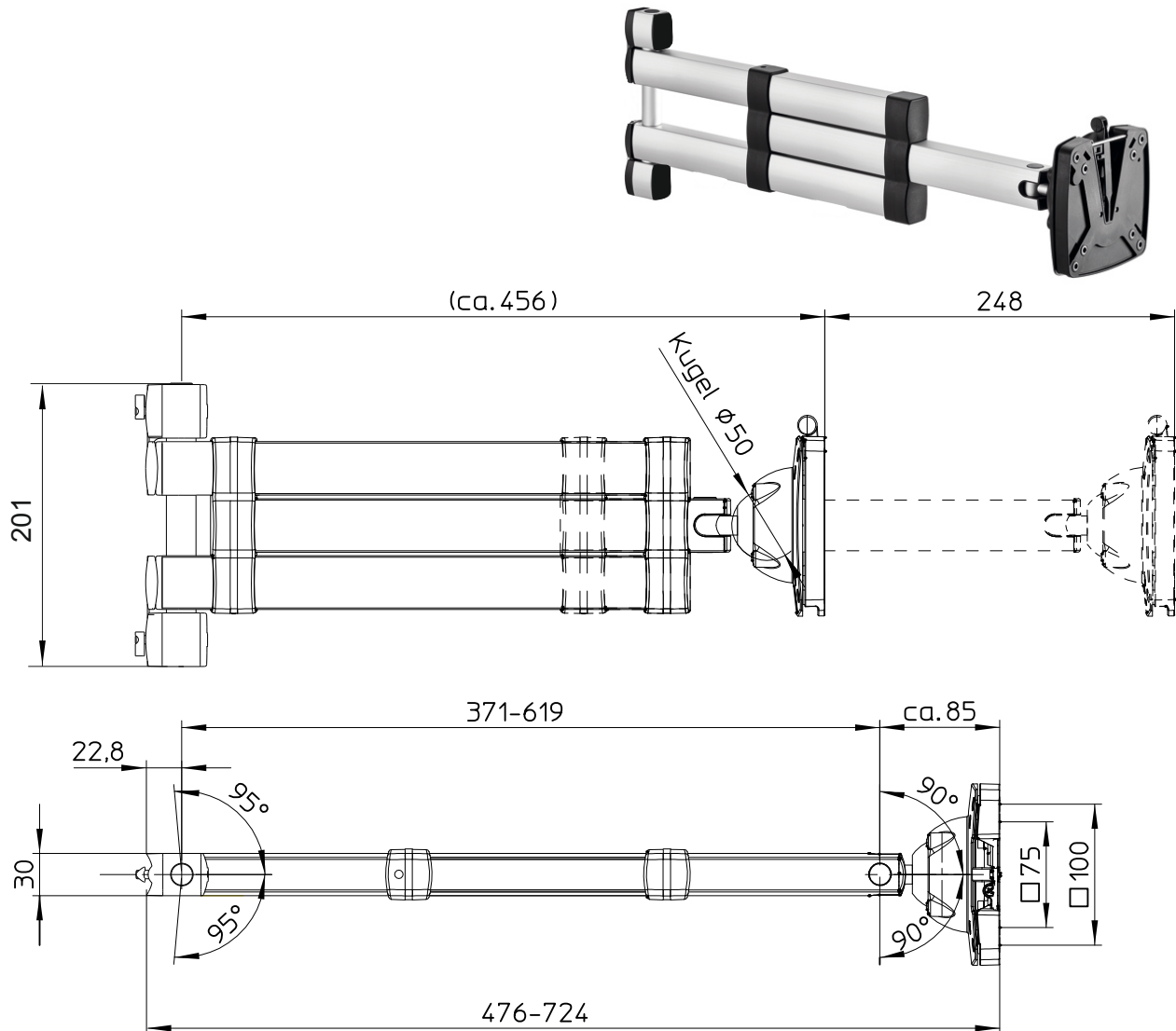

Monitor folding arm



Ref.:	509207		
Width (mm):	100		
Depth (mm):	476-724		
Height (mm):	201		
Net weight (kg):	1.80		

Description: Monitor folding arm

for flexible attachment of a monitor in the system grooves of Rocholz profiles with perforation, on support column (509001,509002, 509006), on profile rail (509005) or upright adapter (509004), incl. cable holder

- VESA 75/100 quick-release attachment
- Load capacity 8 kg



Monitor folding arm

Ref.:	509207			
Number of packets:	1			
EAN:	4030177073176			
Size WxDxH (mm):	530x260x130			
Weight (kg):	2.50			

examples:
optional accessories



Keyboard and mouse platform with folding arm
Ref.:509201



Monitor support carriage
Ref.: 509202



Monitor folding arm
Ref.: 509204



Support column with screw clamp
Ref.: 509002



Profile rail for PC folding arms
Ref.: 509005

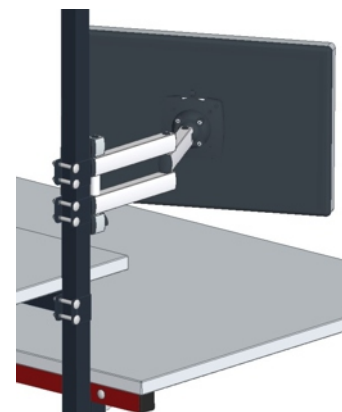

Upright adapter for attaching 509201, 509202, 509203
Ref.: 509003

Upright adapter for attaching 509204
Ref.: 509004