

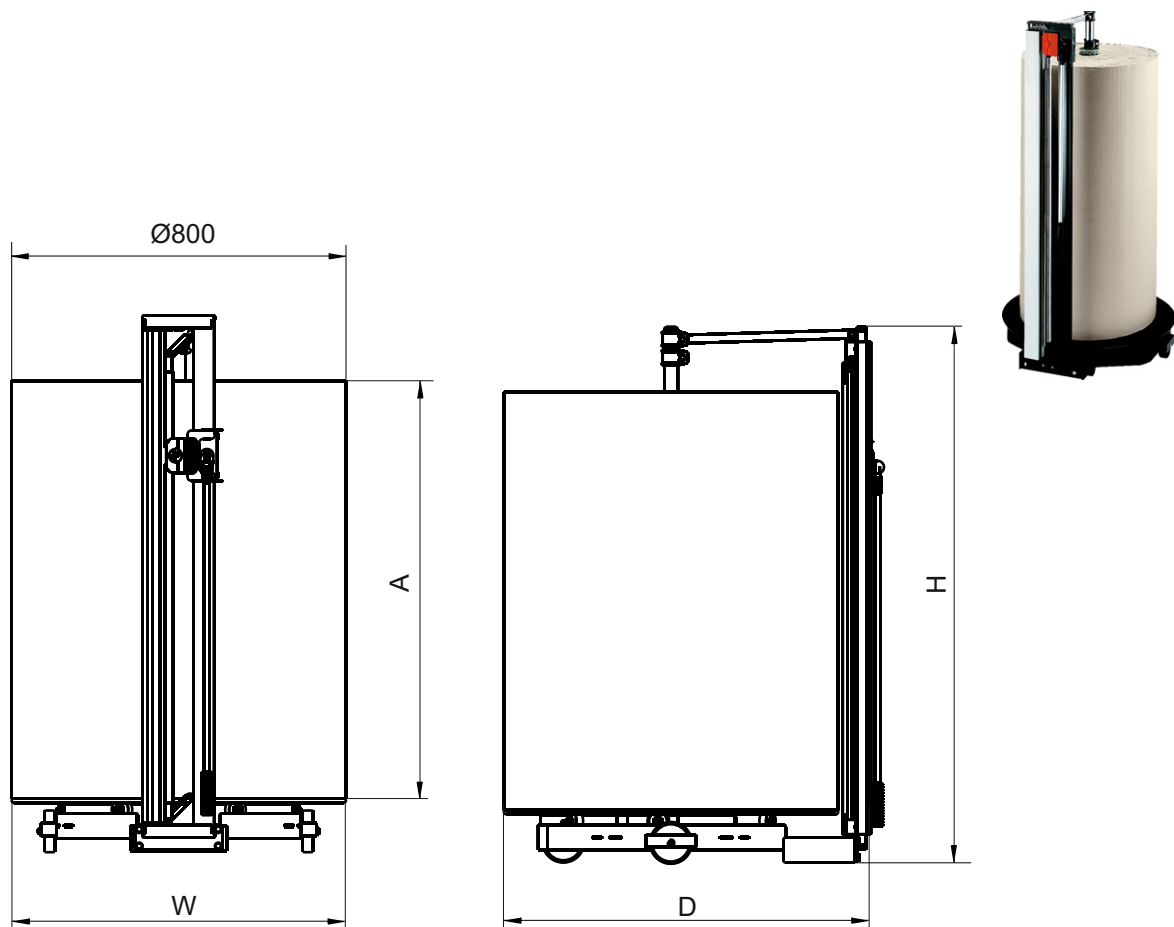

Cutter stand, vertical



Max. roll width A (mm)	1000	1250	1600	1800	2000
Max. roll-diameter (mm)	800	800	800	800	800
Width W (mm):	800	800	800	800	800
Depth D (mm):	880	880	880	880	880
Height H (mm):	1295	1545	1895	2095	2295
Max. roll-weight (kg):	200.00	200.00	200.00	200.00	200.00
Net-weight (kg):	24.20	25.70	27.70	32.10	33.80
Ref.:	35110	35112	35116	35118	35120

Description:

Choose from our proven cutting systems with dispenser for roll material (such as paper, cardboard or foil) for use either as a stand-alone cutting station or right next to the packing workplace. The machinery quickly pays for itself since roll material is cheaper than cuttings.

Not only that, but it also makes the dangerous and time-consuming handling of knives and scissors superfluous.

The cutter cartridges can be exchanged without any effort. The round cutter for paper, cardboard, etc., the blade for all soft foil. A clamping mechanism allows comfortable insertion of the material and safe holding after every cut.

- Timeless dynamic design
- High stability
- Max. roll weight 200 kg
- Max. roll-Ø 800 mm
- incl. 1 cutter cassette with round cutter for paper, cardboard, etc.
- incl. 1 cutter cassette with blades for soft foil



Cutter stand, vertical



Cutting wheel
for paper, cardboard, etc.
Ref. 625010

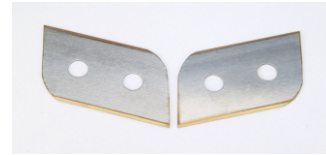

Blade bipartite for cassette
for films, bubble foils etc.
(without fixing plate)
Ref. 6250200



Cassette complete with
cutting wheel for paper,
cardboard, etc.
Ref. 62501



Cassette complete with
blades, bipartite
Ref. 98013417



Cutting slide, vertical with handle
(without cutter cassette)
Best.-Nr. 63500



Set of sliding shoes
for cutting carriage
Ref. 63525

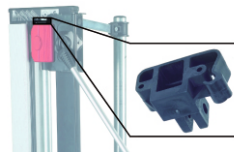

Fastening clamp (black)
for vertical slider
Ref. 63/13



Handle with
plastic suspension
Ref. 63510



Loop with screw
for handle
Ref. 63515



Side guidance (1 pair)
for clamping bar
Ref. 63520



Fastening fork with bolt (1 pair)
for clamping bar
Ref. 63521



Cones with clamping rings
(1 set) for core diameter 60-85mm
Ref. 62/11

Examples:

Optional accessoires

Building block for earthing
for cuttering stand, vertical
Ref. 554



Cutter stand, vertical

Ref.:	35110	35112	35116	35118
EAN:	4030177006020	4030177006051	4030177006075	4030177006099
Net weight (kg)	25.50	27.00	29.00	38.00
Number of packet:	2	2	2	2
Packet 1				
Ref.:	351103	351103	351103	351203
EAN:	4030177006044	4030177006044	4030177006044	4030177006112
Size WxDxH (mm):	850x900x140	850x900x140	850x900x140	850x900x140
Weight (kg):	16.00	16.00	16.00	17.00
Packet 2				
Ref.:	350101	350121	350161	350181
EAN:	4030177005856	4030177005900	4030177005948	4030177005962
Size WxDxH (mm):	1300x250x90	1600x250x90	1900x250x90	2100x250x90
Weight (kg):	9.50	11.00	13.00	17.00

Ref.:	35120			
EAN:	4030177006115			
Net weight (kg)	40.00			
Number of packet:	2			
Packet 1				
Ref.:	351203			
EAN:	4030177006112			
Size WxDxH (mm):	850x900x140			
Weight (kg):	17.00			
Packet 2				
Ref.:	350201			
EAN:	4030177005986			
Size WxDxH (mm):	2300x250x90			
Weight (kg):	18.00			