

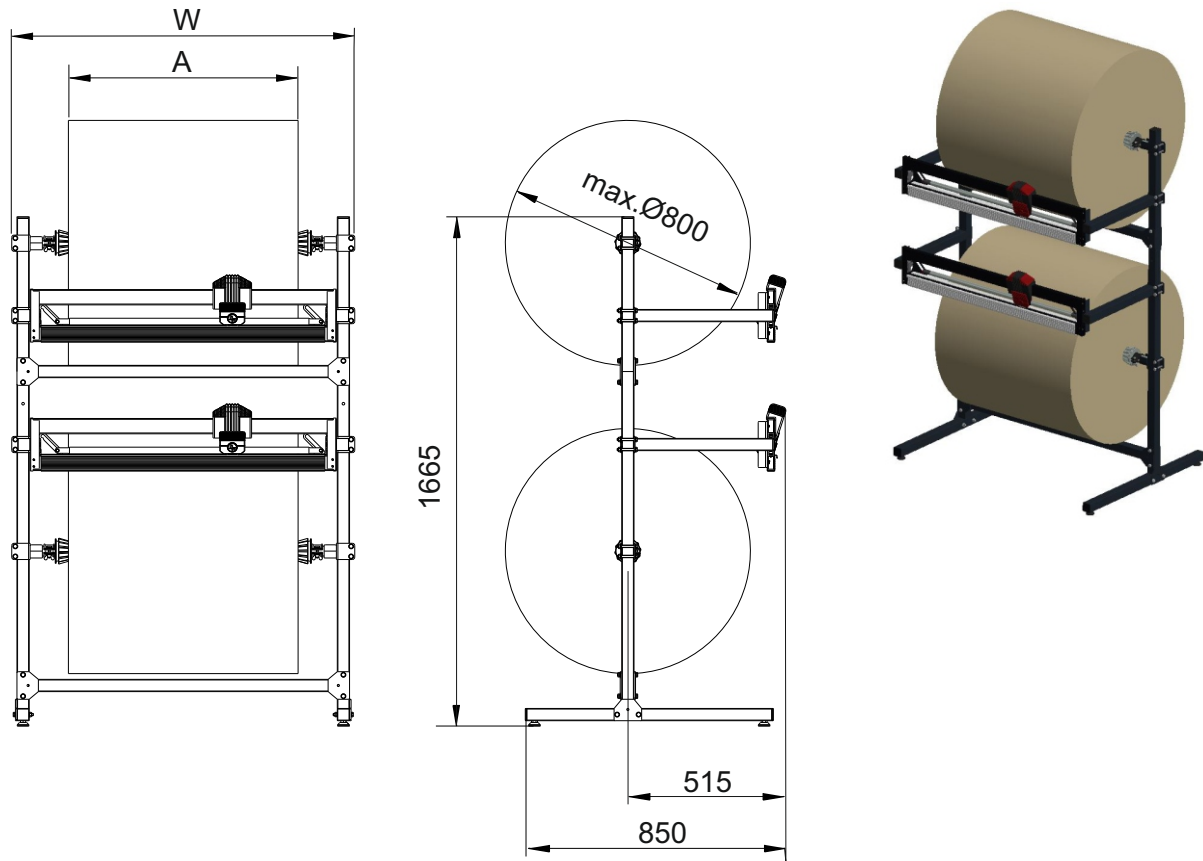

Dual cutter stand



Max. roll width A (mm):	750	1000	1250	1600	1800	2000
Max. roll-diameter (mm):	800	800	800	800	800	800
Width W (mm):	1120	1370	1620	1970	2170	2370
Depth (mm):	850	850	850	850	850	850
Height (mm):	1665	1665	1665	1665	1665	1665
Max. total roll weight (kg):	130.00	130.00	130.00	130.00	130.00	130.00
Net weight (kg):	39.80	45.10	47.50	54.90	65.00	69.00
Ref.:	26407	26410	26412	26416	26418	26420

Description:

Choose from our proven cutting systems with dispenser for roll material (such as paper, cardboard or foil) for use either as a stand-alone cutting station or right next to the packing workplace. The machinery quickly pays for itself since roll material is cheaper than cuttings.

Not only that, but it also makes the dangerous and time-consuming handling of knives and scissors superfluous.

The cutter cartridges can be exchanged without any effort. The round cutter for paper, cardboard, etc., the blade for all soft foil. A clamping mechanism allows comfortable insertion of the material and safe holding after every cut.

- High stability
- With two cutters
- Material outlet height infinitely adjustable
- Max. total roll weight 130 kg
- Max. roll-Ø 800 mm
- incl. 2x cutter cassette with round cutter
- incl. 2x cutter cassette with blades for soft foil -1-



Dual cutter stand



Cutting wheel
for paper, cardboard, etc.
Ref. 625010



Cassette complete with
cutting wheel for paper,
cardboard, etc.
Ref. 62501



Cutting slide, horizontal
(without cutter cassette)
Ref. 62500

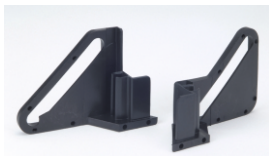

Side guidance (1 pair)
for clamping bar
Ref. 63520



Cones with clamprings
(1 set) for core diameter 60-85mm
Ref. 62/11

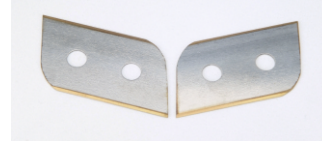

Blade bipartite for cassette
for films, bubble foils etc.
(without fixing plate)
Ref. 6250200



Cassette complete with
blades, bipartite
Ref. 62502 N



Set of sliding shoes
for cutting carriage
Ref. 63525



Fastening fork with bolt (1 pair)
for clamping bar
Ref. 63521

Examples:
Optional accessoires

Earthing device for dual cutter stand
Ref. 552



Swivel castors (1 set) for
cutting stand no. 262.., 264.., 265..
Ref. 23601



Dual cutter stand

Ref.	26407	26410	26412	26416
EAN:	4030177022792	4030177022808	4030177022815	4030177005672
Net weight (kg)	45.00	50.00	52.00	60.00
Number of packet:	6	6	6	6
Packet 1				
Ref.:	26200/1N	26200/1N	26200/1N	26200/1N
EAN:	4030177022884	4030177022884	4030177022884	4030177022884
Size WxDxH (mm):	460x1150x100	460x1150x100	460x1150x100	460x1150x100
Weight (kg):	16.00	16.00	16.00	16.00
Packet 2				
Ref.:	26400/1	26400/1	26400/1	26400/1
EAN:	4030177022990	4030177022990	4030177022990	4030177022990
Size WxDxH (mm):	200x590x140	200x590x140	200x590x140	200x590x140
Weight (kg):	7.80	7.80	7.80	7.80
Packet 3 (2x)				
Ref.:	25007/2N	25010/2N	25012/2N	25016/2N
EAN:	4030177022891	4030177022907	4030177022914	4030177022921
Size WxDxH (mm):	100x1100x50	100x1350x50	100x1640x50	100x1950x50
Weight (kg):	2.70	3.60	4.10	5.10
Packet 4 (2x)				
Ref.:	250071	250101	250121	250161
EAN:	4030177004385	403017704408	4030177034719	4030177004446
Size WxDxH (mm):	250x1000x90	250x1300x90	250x1600x90	250x1900x90
Weight (kg):	7.50	9.50	10.00	13.00

Ref.:	26418	26420		
EAN:	4030177005689	4030177022822		
Net weight (kg)	67.00	72.00		
Number of packet:	6	6		
Packet 1				
Ref.:	26200/1N	26200/1N		
EAN:	4030177022884	4030177022884		
Size WxDxH (mm):	460x1150x100	460x1150x100		
Weight (kg):	16.00	16.00		
Packet 2				
Ref.:	26400/1	26400/1		
EAN:	4030177022990	4030177022990		
Size WxDxH (mm):	200x590x140	200x590x140		
Weight (kg):	7.80	7.80		



Dual cutter stand

Packet 3 (2x) Ref.:	25018/2N	25020/2N		
EAN:	4030177023782	4030177022938		
Size WxDxH (mm):	100x2150x50	100x2300x50		
Weight (kg):	5.50	5.90		
Packet 4 (2x) Ref.:	250181	250201		
EAN:	4030177004453	4030177004477		
Size WxDxH (mm):	250x2100x90	250x2300x90		
Weight (kg):	16.00	18.00		