

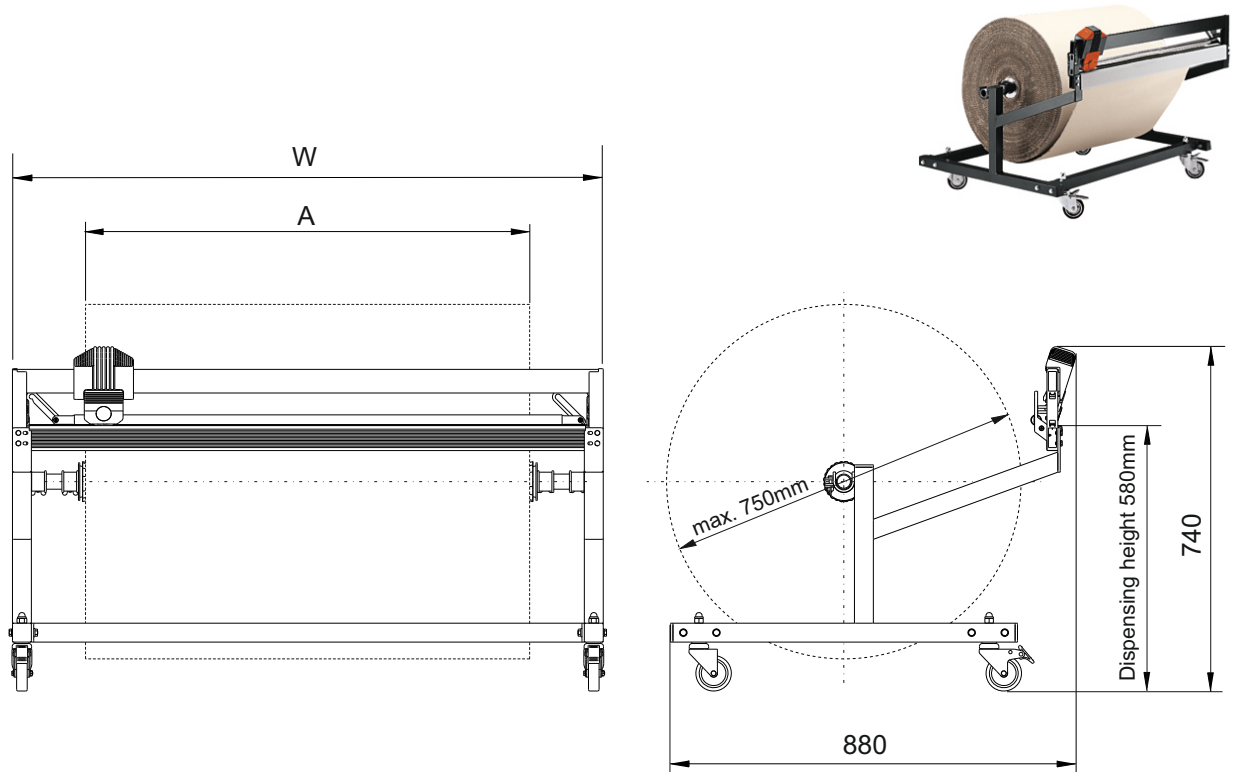

SYSTEM mobile under-table cutter stand



max. roll width A (mm)	750	1000	1250	1600		
max. roll-diameter (mm)	750	750	750	750		
Width W (mm):	1000	1250	1500	1850		
Depth (mm):	880	880	880	880		
Height (mm):	740	740	740	740		
max.roll weight (kg):	200.00	200.00	200.00	200.00		
Net weight (kg):	20.70	23.80	24.50	29.30		
Ref.:	25507	25510	25512	25516		

Description:

Choose from our proven cutting systems with dispenser for roll material (such as paper, cardboard or foil) for use either as a stand-alone cutting station or right next to the packing workplace. The machinery quickly pays for itself since roll material is cheaper than cuttings.

Not only that, but it also makes the dangerous and time-consuming handling of knives and scissors superfluous.

The cutter cartridges can be exchanged without any effort. The round cutter for paper, cardboard, etc., the blade for all soft foil. A clamping mechanism allows comfortable insertion of the material and safe holding after every cut.

- High stability
- Dispensing height 890mm
- Max. roll weight 200 kg
- Max. roll-Ø 1000 mm
- incl. 1 cutter cassette with round cutter
- incl. 1 cutter cassette with blades for soft foil



SYSTEM mobile under-table cutter stand



Cutting wheel
for paper, cardboard, etc.
Ref. 625010



Cassette complete with
cutting wheel for paper,
cardboard, etc.
Ref. 62501



Cutting slide, horizontal
(without cutter cassette)
Ref. 62500

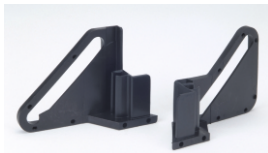

Side guidance (1 pair)
for clamping bar
Ref. 63520



Cones with clamping rings
(1 set) for core diameter 60-85mm
Ref. 62/11

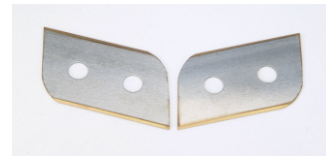

Blade bipartite for cassette
for films, bubble foils etc.
(without fixing plate)
Ref. 6250200



Cassette complete with
blades, bipartite
Ref. 62502N

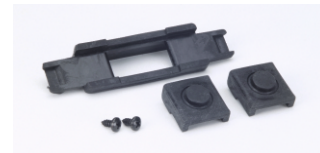

Set of sliding shoes
for cutting carriage
Ref. 63525



Fastening fork with bolt (1 pair)
for clamping bar
Ref. 63521

SYSTEM mobile under-table cutter stand

Ref.	25507	25510	25512	25516
EAN:	4030177004859	4030177004873	4030177004897	4030177004910
Net weight (kg)	23.00	26.00	28.00	32.00
Number of packet:	3	4	4	4
Packet 1	(1x)	(1x)	(1x)	(1x)
Ref.:	25500/1	25500/1	25500/1	25500/1
EAN:	4030177004842	4030177004842	4030177004842	4030177004842
Size WxDxH (mm):	850x500x100	850x500x100	850x500x100	850x500x100
Weight (kg):	10.60	10.60	10.60	10.60
Packet 2	(1x)	(2x)	(2x)	(2x)
Ref.:	25507/2	25010/2	25012/2	25016/2
EAN:	4030177004866	4030177016296	4030177016302	4030177016319
Size WxDxH (mm):	950x100x100	1200x100x50	1450x100x50	1800x100x50
Weight (kg):	4.70	3.00	3.60	4.00
Packet 3	(1x)	(1x)	(1x)	(1x)
Ref.:	250071	250101	250121	250161
EAN:	4030177004385	403017704408	4030177034719	4030177004446
Size WxDxH (mm):	250x1000x90	250x1300x90	250x1600x90	250x1900x90
Weight (kg):	7.50	9.50	10.00	13.00