

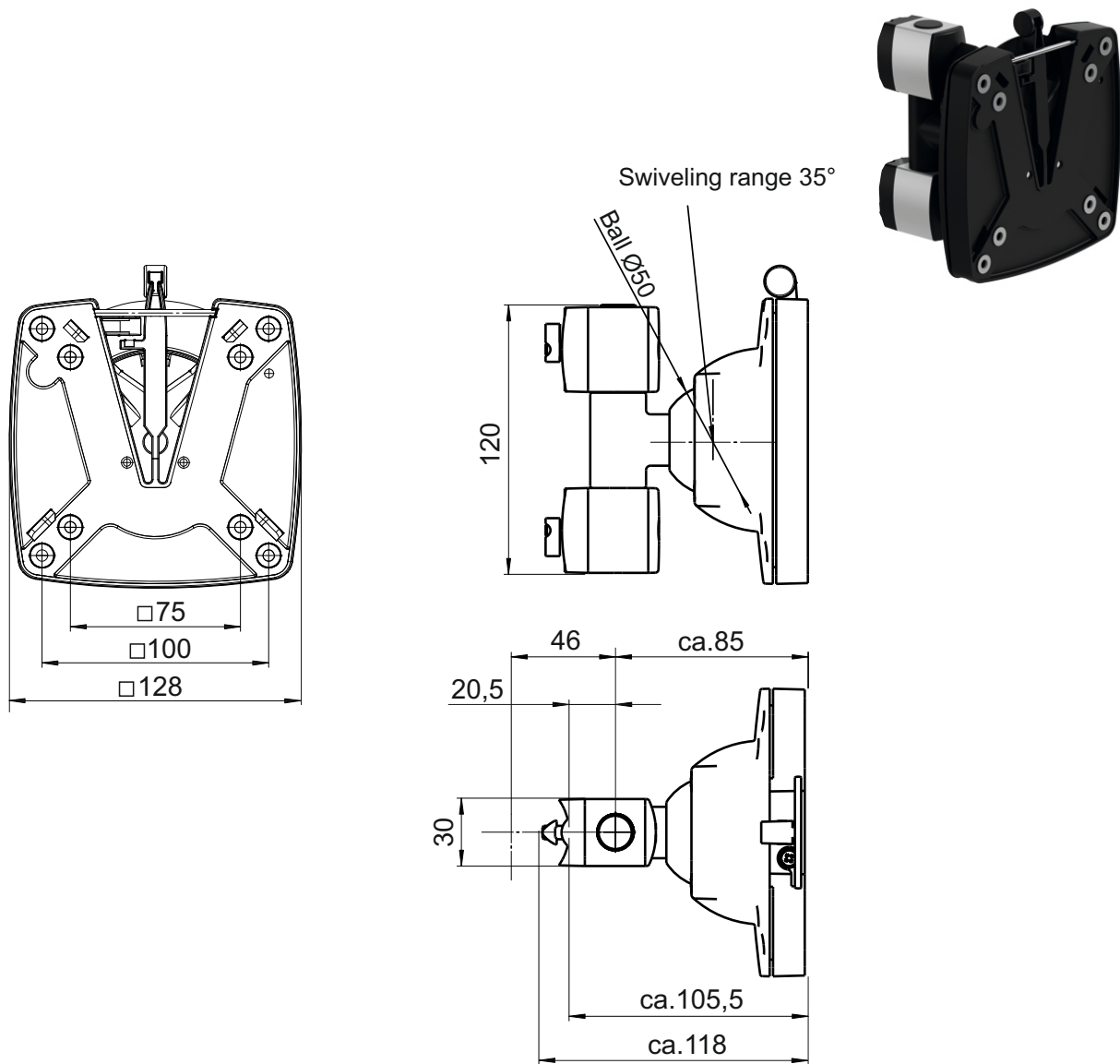

Monitor support carriage



Ref.:	509202		
Width (mm):	128		
Depth (mm):	118		
Height (mm):	128		
Net weight (kg):	1.00		

Description:
 Monitor support carriage

for flexible attachment of a monitor to the support column, profile rail, in the system groove of the Rocholz profiles with perforation or on a upright adapter (509003)

- VESA 75/100 quick-release attachment
- Load capacity 12 kg



Monitor support carriage

Ref.:	509202			
Number of packets:	1			
EAN:	4030177031879			
Size BxDxH (mm):	190x210x130			
Gewicht (kg):	1.00			

Examples:
Optional accessories



Keyboard and mouse platform with folding arm
Ref.:509201



Monitor folding arm
Ref.: 509203



Monitor folding arm
Ref.: 509204



Support column with screw clamp
Ref.: 509002

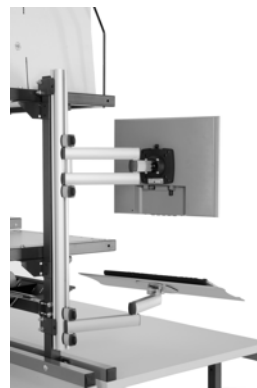

Profile rail for folding arms for IT
Ref.: 509005

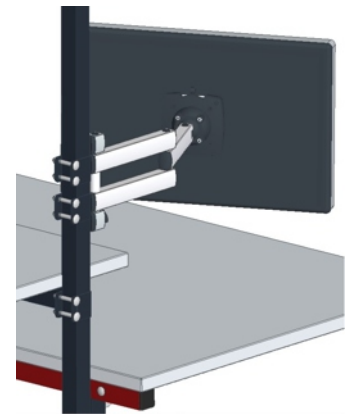

Upright adapter for attaching 509201, 509202, 509203
Ref.: 509003

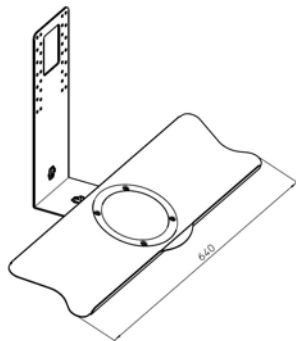

Keyboard adapter for mounting at screen folding arm
Ref.: 509205

Upright adapter for attaching 509204, 509207, 509209
Ref.: 509004

All information / dimensions approx., techn. information subject to change • as of: 01/2025