

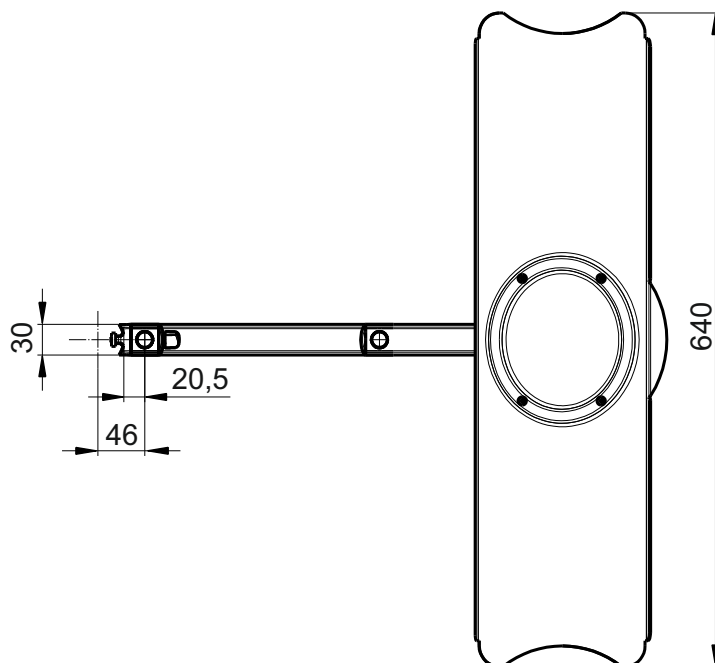

Keyboard and mouse platform with folding arm

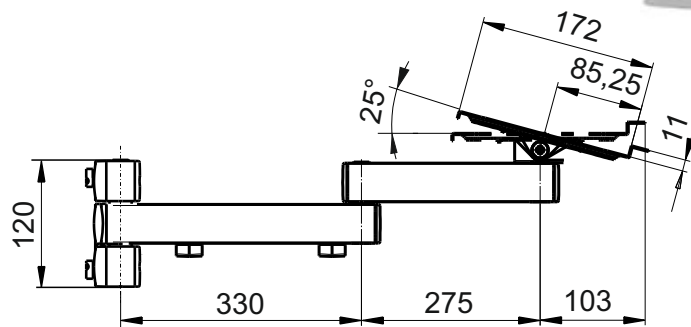

Ref.:	509201		
Width (mm):	640		
Depth (mm):	708		
Height (mm):	120		
Net weight (kg):	2.80		

Description:

Keyboard and mouse platform with folding arm

for flexible mounting in the system grooves of Rocholz mounting profiles with perforation, on support column (509001, 509002, 509006), on profile rail (509005) or on upright adapter (509003).

- Platform 640 x 172 mm, tiltable up to 25°
- rotatable and swivelling
- max. reach 728 mm
- max. surface load 10 kg



Keyboard and mouse platform with folding arm

Ref.:	509201			
Number of packets:	1			
EAN:	4030177031862			
Size WxDxH (mm):	260x660x160			
Weight (kg):	3.50			

Examples:
optional accessories



Monitor support carriage
Ref.: 509202



Monitor folding arm
Ref.: 509203



Monitor folding arm
Ref.: 509204



Support column with
screw clamp
Ref.: 509002

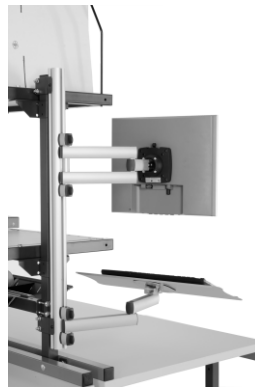

Profile rail for PC folding arms
Ref.: 509005

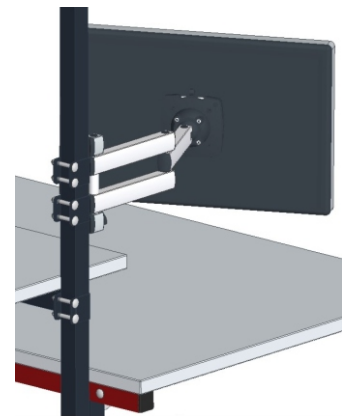

Upright adapter for attaching
509201, 509202, 509203
Ref.: 509003

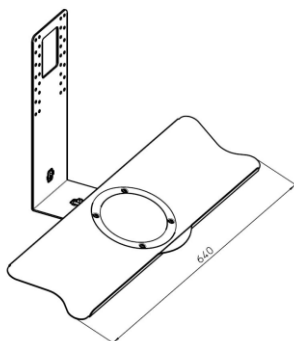

Keyboard adapter for
mounting at screen folding arm
Ref.: 509205

Upright adapter for attaching
509204
Ref.: 509004

All information / dimensions approx., techn. information subject to change • as of: 01/2024