

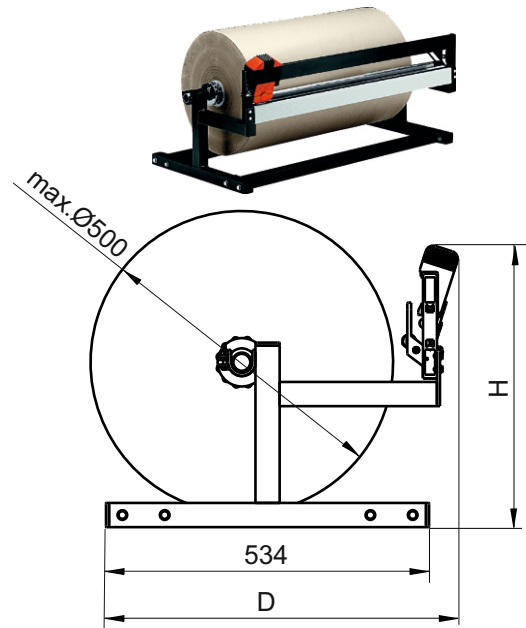

## SYSTEM table-top cutting system

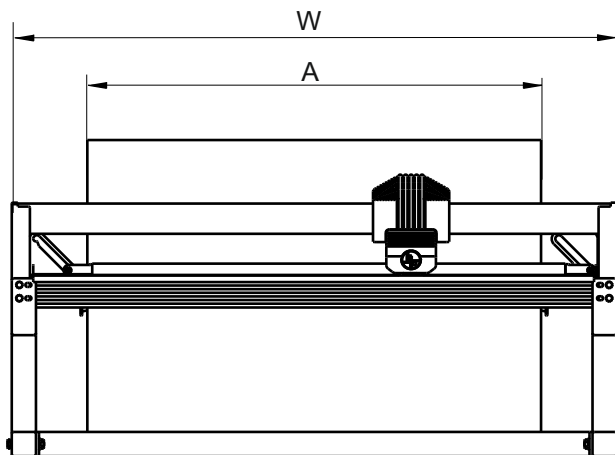

max. roll width A (mm)	<b>750</b>	<b>1000</b>	<b>1250</b>	<b>1600</b>	-	-
max. rollen-Ø (mm)	500	500	500	500	-	-
Width W (mm):	1000	1250	1500	1850	-	-
Depth D (mm):	582	582	582	582	-	-
Height H (mm):	465	465	465	465	-	-
max. roll weight (kg):	200	200	200	200	-	-
Net weight (kg):	17.40	20.60	22.30	26.00	-	-
Ref.:	<b>25707</b>	<b>25710</b>	<b>25712</b>	<b>25716</b>	-	-

### Description:

Choose from our proven cutting systems with dispenser for roll material (such as paper, cardboard or foil) for use either as a stand-alone cutting station or right next to the packing workplace. The machinery quickly pays for itself since roll material is cheaper than cuttings.

Not only that, but it also makes the dangerous and time-consuming handling of knives and scissors superfluous.

The cutter cartridges can be exchanged without any effort. The round cutter for paper, cardboard, etc., the blade for all soft foil. A clamping mechanism allows comfortable insertion of the material and safe holding after every cut.

- Spindle Ø 32 mm
- 
- Max. roll weight 200 kg
- 
- Max. roll-Ø 500 mm
- 
- incl. 1 cutter cassette with round cutter for paper, cardboard, etc.
- 
- incl. 1 cutter cassette with blades for soft foil



SYSTEM table-top cutting system



Cutting wheel  
for paper, cardboard, etc.  
Ref. 625010



Cassette complete with  
cutting wheel for paper,  
cardboard, etc.  
Ref. 62501



Cutting slide, horizontal  
(without cutter cassette)  
Ref. 62500

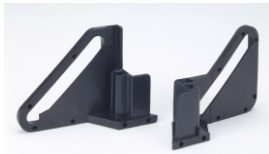

Side guidance (1 pair)  
for clamping bar  
Ref. 63520



Cones with clamprings  
(1 set) for core diameter 60-85mm  
Ref. 62/11

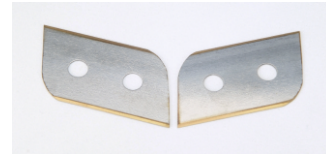

Blade bipartite for cassette  
for films, bubble foils etc.  
(without fixing plate)  
Ref. 6250200



Cassette complete with  
blades, bipartite  
Ref. 62502N



Set of sliding shoes  
for cutting carriage  
Ref. 63525



Fastening fork with bolt (1 pair)  
for clamping bar  
Ref. 63521

**SYSTEM table-top cutting system**

<b>Ref.:</b>	<b>25707</b>	<b>25710</b>	<b>25712</b>	<b>25716</b>
<b>EAN:</b>	<b>4030177005054</b>	<b>4030177005078</b>	<b>4030177005092</b>	<b>4030177005115</b>
<b>Net weight (kg)</b>	<b>19.00</b>	<b>22.00</b>	<b>24.00</b>	<b>28.00</b>
Number of packets:	4	4	4	4
Packet 1				
Ref.:	25700/1	25700/1	25700/1	25700/1
EAN:	4030177005047	4030177005047	4030177005047	4030177005047
Size WxDxH (mm):	320x570x90	320x570x90	320x570x90	320x570x90
Weight (kg):	6.80	6.80	6.80	6.80
Packet 2 (2x)				
Ref.:	25007/2	25010/2	25012/2	25016/2
EAN:	4030177016289	4030177016296	4030177016302	4030177016319
Size WxDxH (mm):	100x950x50	100x1200x50	100x1450x50	100x1800x50
Weight (kg):	2.40	3.00	3.60	4.00
Packet 3				
Ref.:	250071	250101	250121	250161
EAN:	4030177004385	403017704408	4030177034719	4030177004446
Size WxDxH (mm):	250x1000x90	250x1300x90	250x1600x90	250x1900x90
Weight (kg):	7.50	9.50	10.00	13.00