

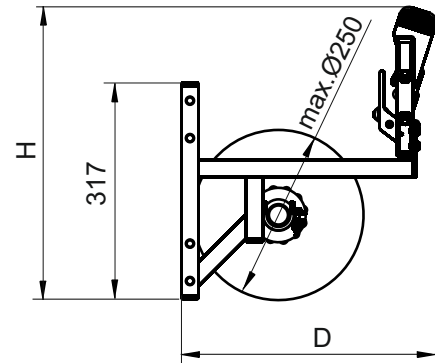

## SYSTEM wall-mounted cutting system

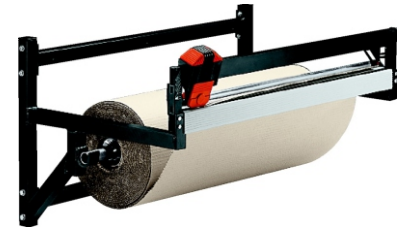
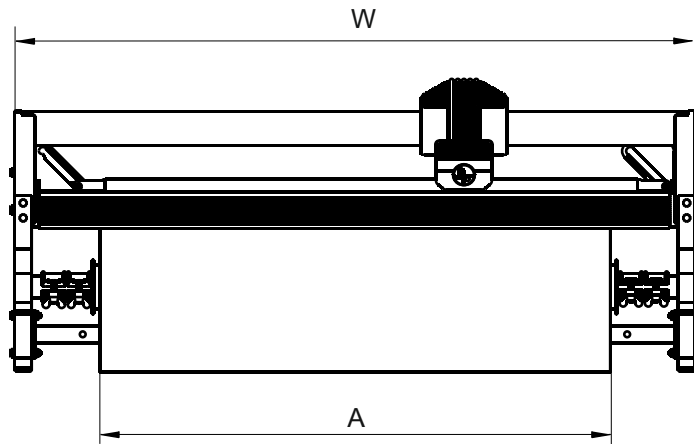

max. roll width A (mm)	<b>750</b>	<b>1000</b>	<b>1250</b>	<b>1600</b>		
max. roll-diameter (mm)	250	250	250	250		
Width W (mm):	1000	1250	1500	1850		
Depth D (mm):	375	375	375	375		
Height H (mm):	428	428	428	428		
max.roll weight (kg):	80.00	80.00	80.00	80.00		
Net weight (kg):	12.80	15.50	16.70	20.60		
Ref.:	<b>25907</b>	<b>25910</b>	<b>25912</b>	<b>25916</b>		

### Description:

Choose from our proven cutting systems with dispenser for roll material (such as paper, cardboard or foil) for use either as a stand-alone cutting station or right next to the packing workplace. The machinery quickly pays for itself since roll material is cheaper than cuttings.

Not only that, but it also makes the dangerous and time-consuming handling of knives and scissors superfluous.

The cutter cartridges can be exchanged without any effort. The round cutter for paper, cardboard, etc., the blade for all soft foil. A clamping mechanism allows comfortable insertion of the material and safe holding after every cut.

- Spindle Ø 32 mm
- 
- Max. roll weight 80 kg
- 
- Max. roll-Ø 250 mm
- 
- incl. 1 cutter cassette with round cutter for paper, cardboard, etc.
- 
- incl. 1 cutter cassette with blades for soft foil
- 
- Mounting materials not included



**SYSTEM wall-mounted cutting system**



Cutting wheel  
for paper, cardboard, etc.  
Ref. 625010



Cassette complete with  
cutting wheel for paper,  
cardboard, etc.  
Ref. 62501



Cutting slide, horizontal  
(without cutter cassette)  
Ref. 62500



Side guidance (1 pair)  
for clamping bar  
Ref. 63520



Cones with clamping rings  
(1 set) for core diameter 60-85mm  
Ref. 62/11

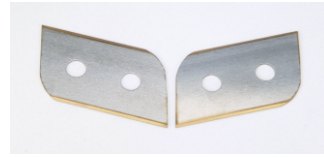

Blade bipartite for cassette  
for films, bubble foils etc.  
(without fixing plate)  
Ref. 6250200



Cassette complete with  
blades, bipartite  
Ref. 62502N



Set of sliding shoes  
for cutting carriage  
Ref. 63525



Fastening fork with bolt (1 pair)  
for clamping bar  
Ref. 63521

**SYSTEM wall-mounted cutting system**

<b>Ref.</b>	<b>25907</b>	<b>25910</b>	<b>25912</b>	<b>25916</b>
<b>EAN:</b>	<b>4030177005184</b>	<b>4030177005207</b>	<b>4030177005221</b>	<b>4030177005245</b>
<b>Net weight (kg)</b>	<b>14.20</b>	<b>16.90</b>	<b>18.20</b>	<b>22.30</b>
Number of packet:	3	3	3	3
Packet 1				
Ref.:	25900/1	25900/1	25900/1	25900/1
EAN:	4030177005177	4030177005177	4030177005177	4030177005177
Size WxDxH (mm):	400x400x100	400x400x100	400x400x100	400x400x100
Weight (kg):	3.80	3.80	3.80	3.80
Packet 2				
Ref.:	25607/2	25610/2	25612/2	25616/2
EAN:	4030177004972	4030177004996	4030177005016	4030177005030
Size WxDxH (mm):	100x950x70	100x1200x70	100x1450x70	100x1800x70
Weight (kg):	2.90	3.60	4.40	5.50
Packet 3				
Ref.:	250071	250101	250121	250161
EAN:	4030177004385	403017704408	4030177034719	4030177004446
Size WxDxH (mm):	250x1000x90	250x1300x90	250x1600x90	250x1900x90
Weight (kg):	7.50	9.50	10.00	13.00